

Three-dimensional coordinate systems

Notation

\mathbb{R} is the set of real numbers

What is a real number?

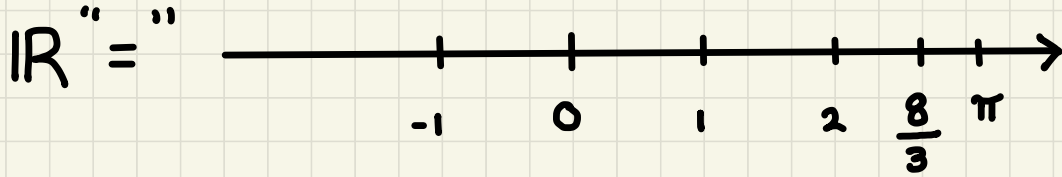

This visual representation is called the **real line** for the obvious reason

\mathbb{R}^2 is the set of ordered pairs
of real numbers

Formally, $\mathbb{R}^2 = \{ (a, b) : a, b \in \mathbb{R} \}$

For example, $(3, 1) \neq (1, 3)$

\mathbb{R}^2 " = "

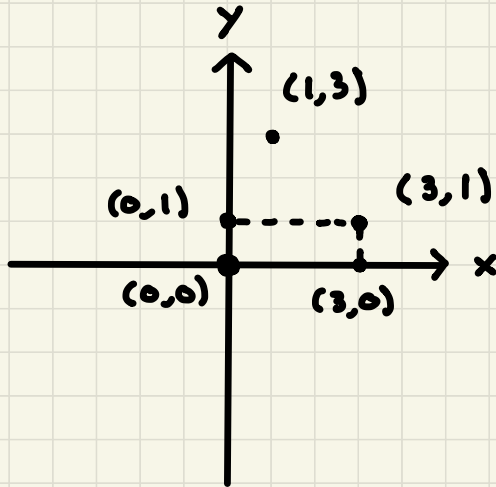

This visual
representation
of \mathbb{R}^2 is
called the plane

More generally, $\mathbb{R}^n = \{(a_1, \dots, a_n) : a_1, \dots, a_n \in \mathbb{R}\}$

\mathbb{R}^n " = " ?

We will consider the case of $n=3$

Formally, $\mathbb{R}^3 = \{(a, b, c) : a, b, c \in \mathbb{R}\}$

↓

ordered triple

$$\mathbb{R}^3 = \{ (a, b, c) : a, b, c \in \mathbb{R} \}$$

$(4, 7, 1)$

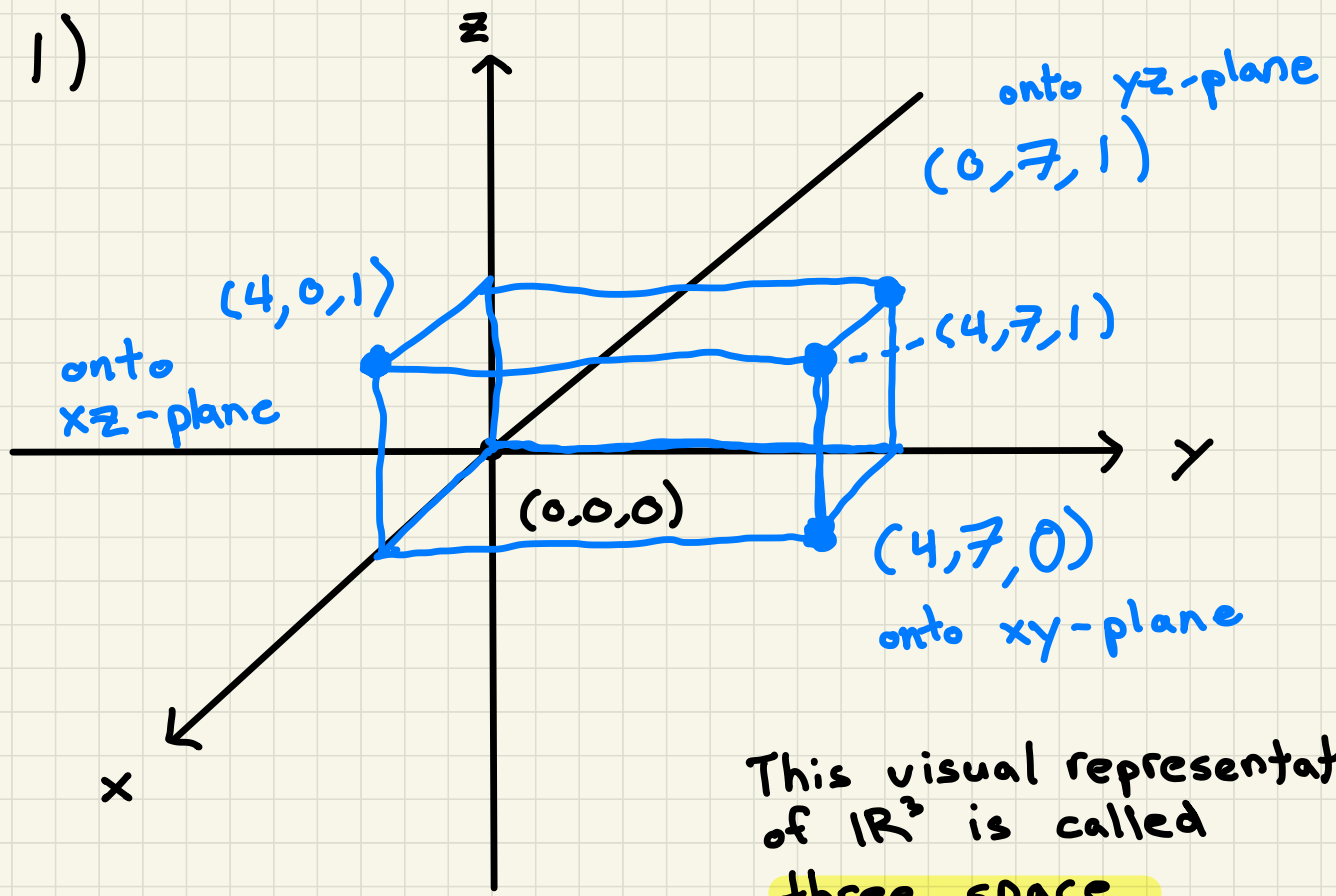

This visual representation of \mathbb{R}^3 is called **three space**

Graphing equations

$$x=2$$

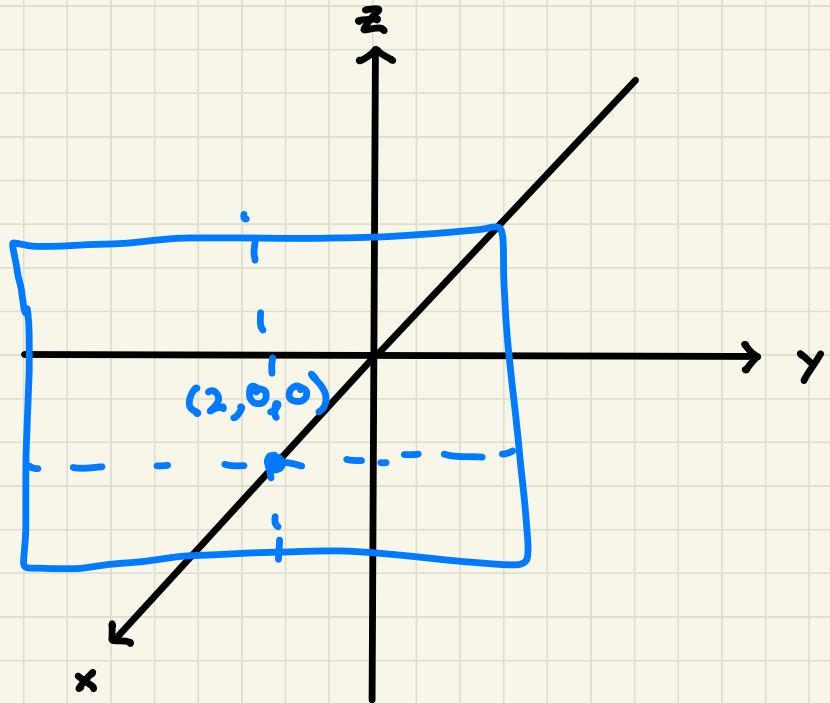
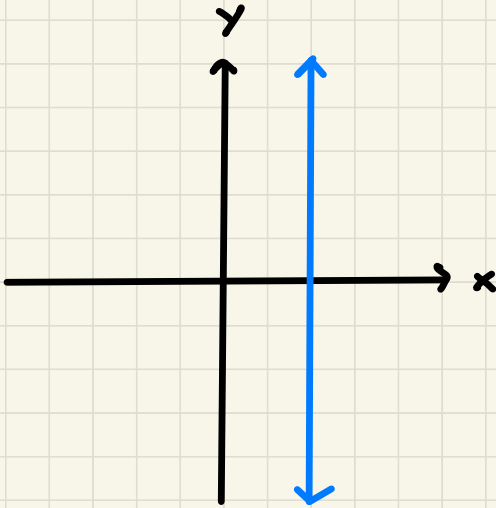

Graphing equations

$$y = -5$$

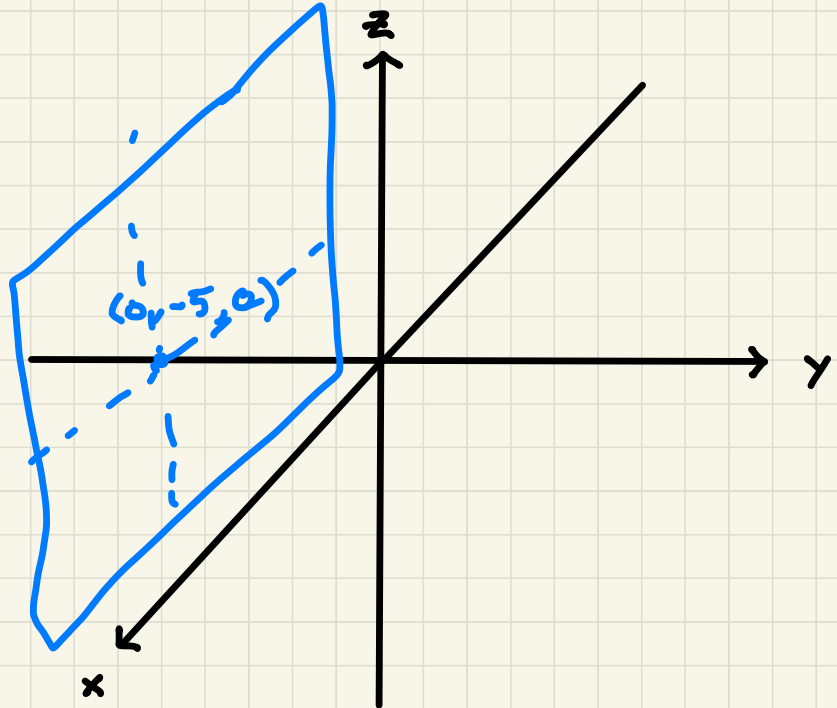
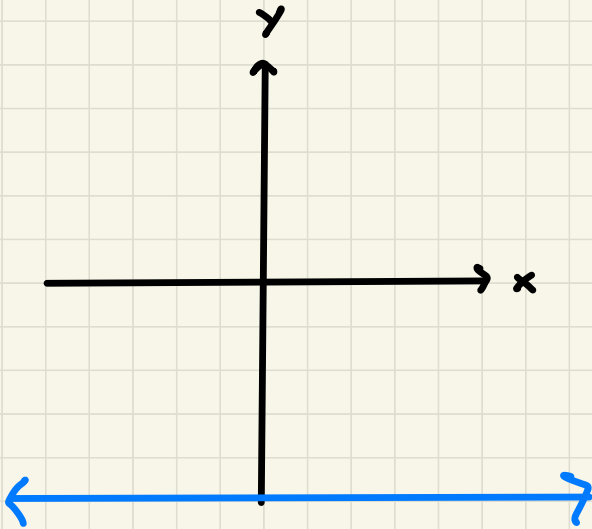

Graphing equations

$$z = \pi$$

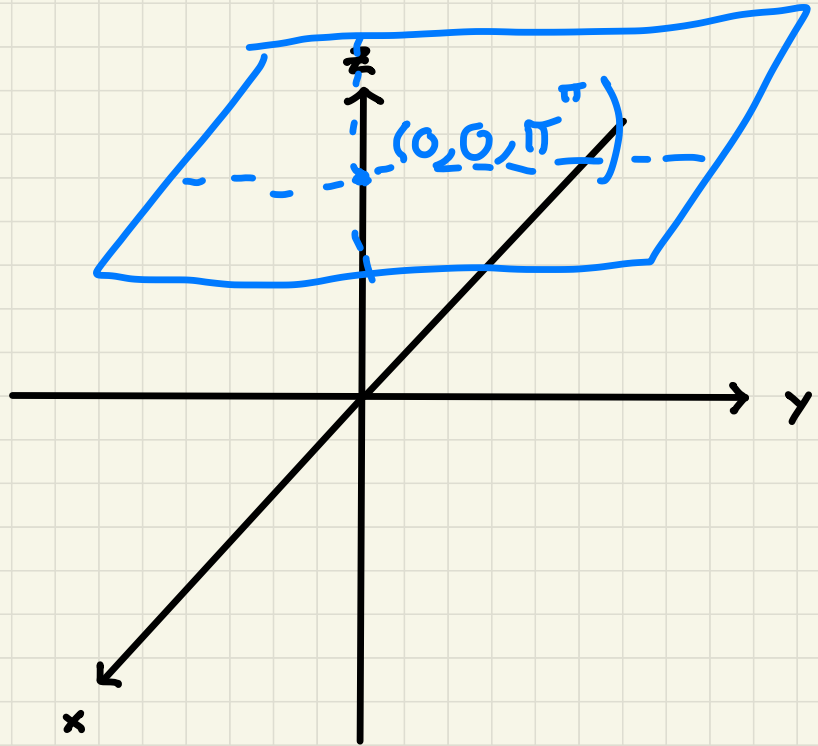
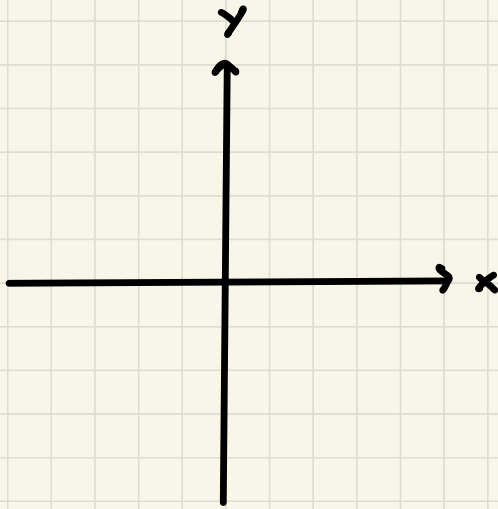

Moral: anything not specified is a free variable

Graphing equations

$$y = x^2$$

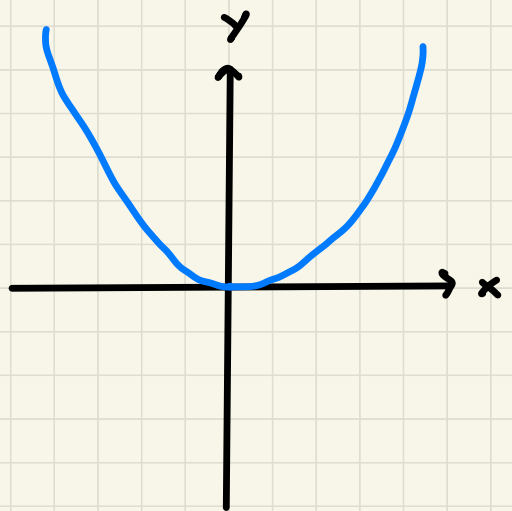

curve

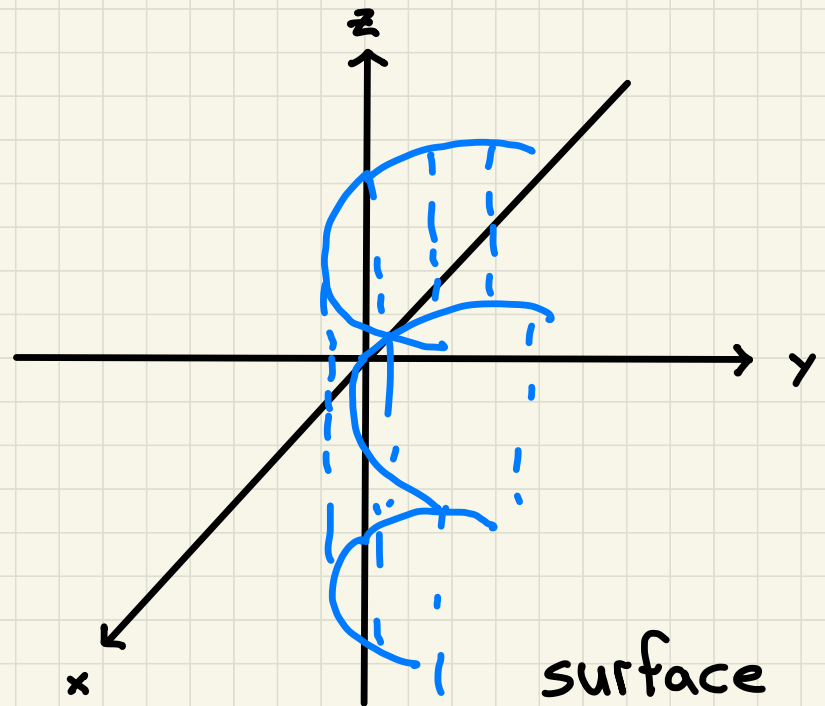

surface

Distance between points

in the plane \mathbb{R}^2

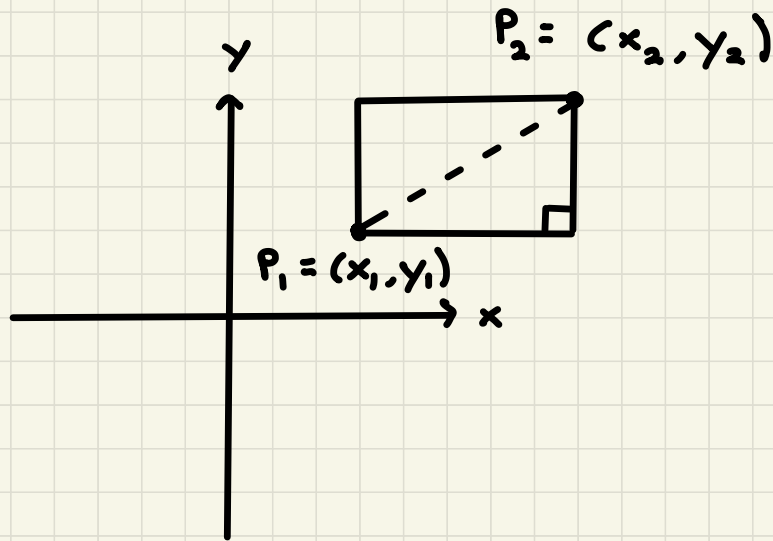

$$\begin{aligned} |P_1, P_2| &= \sqrt{(x_2 - x_1)^2 + (y_2 - y_1)^2} \\ &= |P_2, P_1| \end{aligned}$$

Distance between points

in three space \mathbb{R}^3

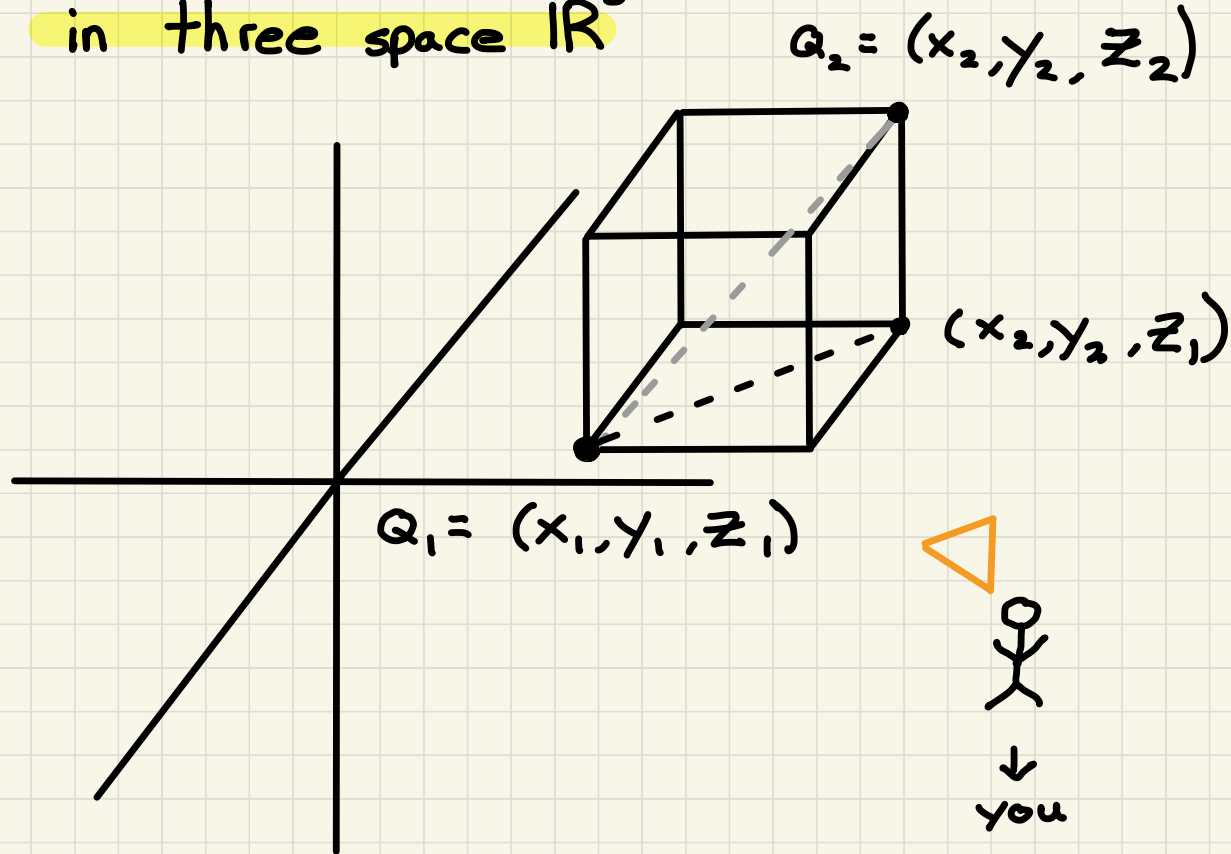
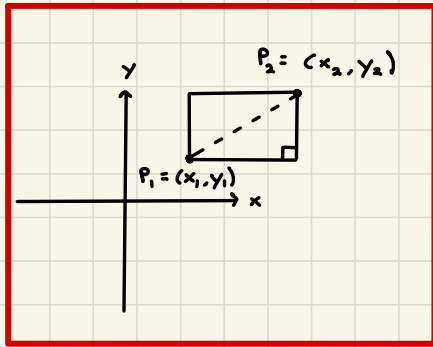

Distance between points

in three space \mathbb{R}^3

What you see

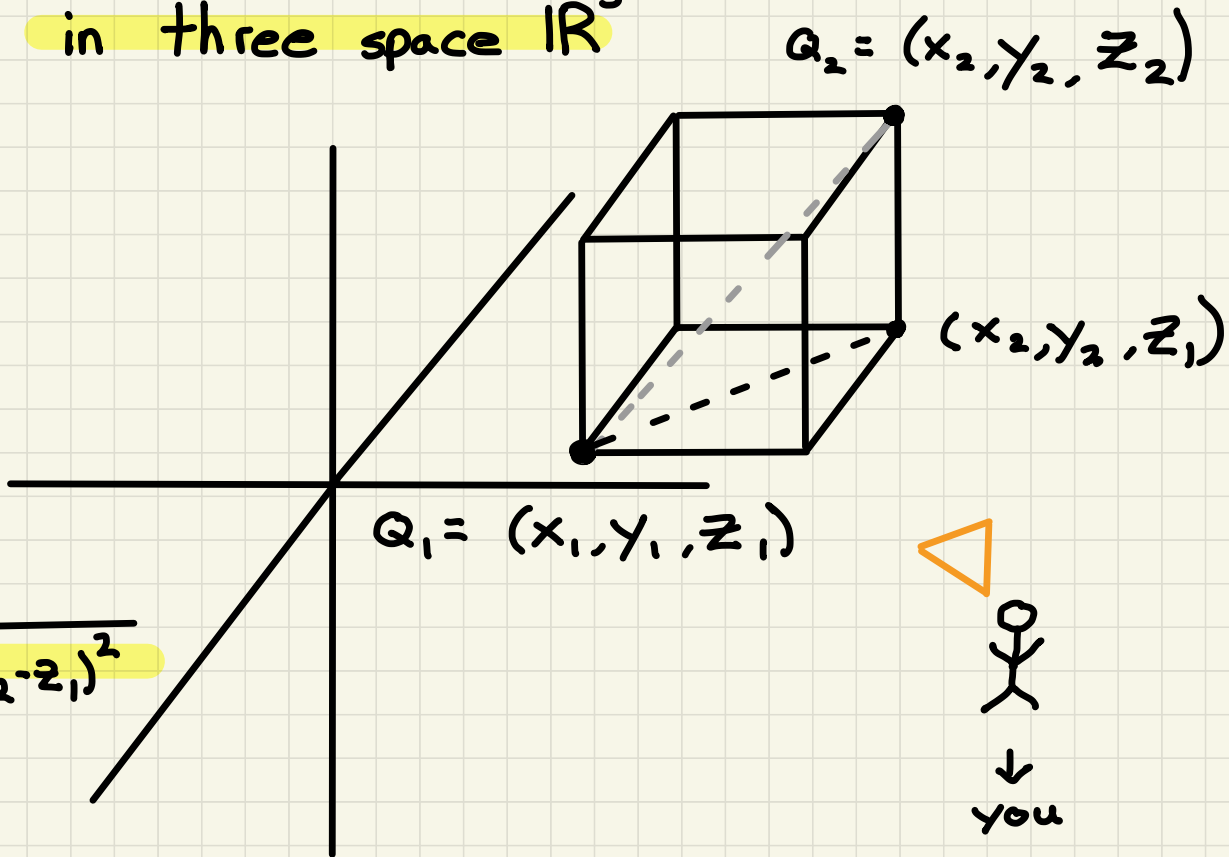
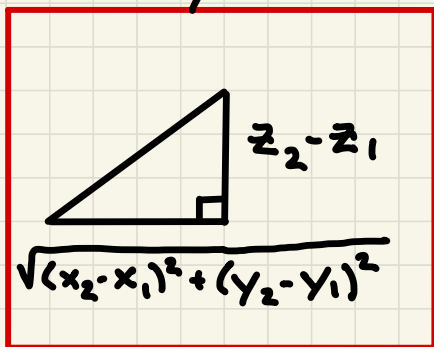

$|Q_1, Q_2|$

$$= \sqrt{(x_2 - x_1)^2 + (y_2 - y_1)^2 + (z_2 - z_1)^2}$$

Graphing equations

$$(x-x_0)^2 + (y-y_0)^2 = r^2$$

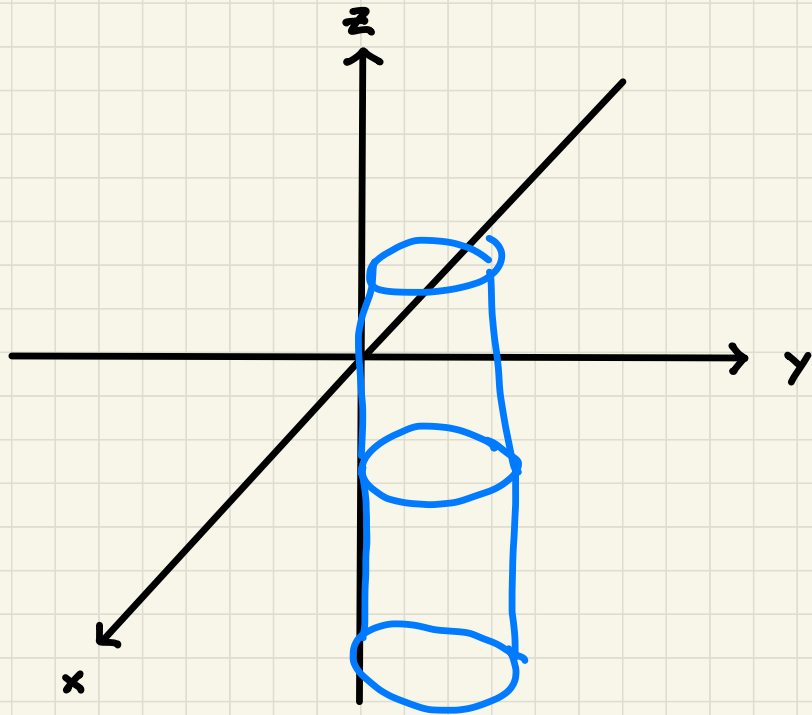
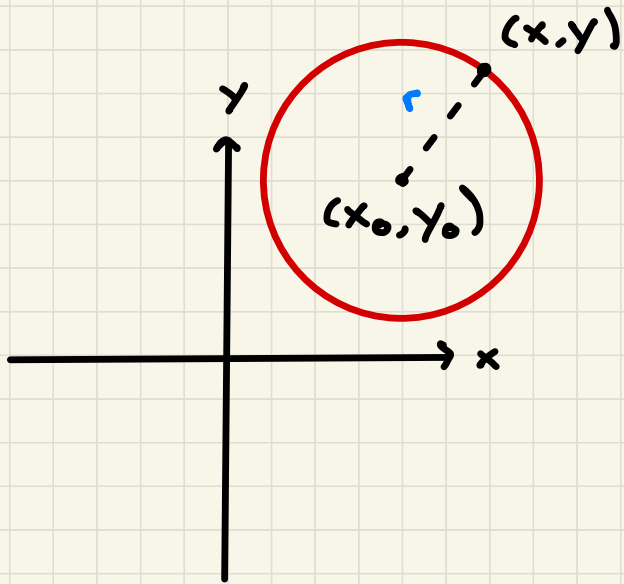

Graphing equations

$$(x-x_0)^2 + (y-y_0)^2 = r^2$$

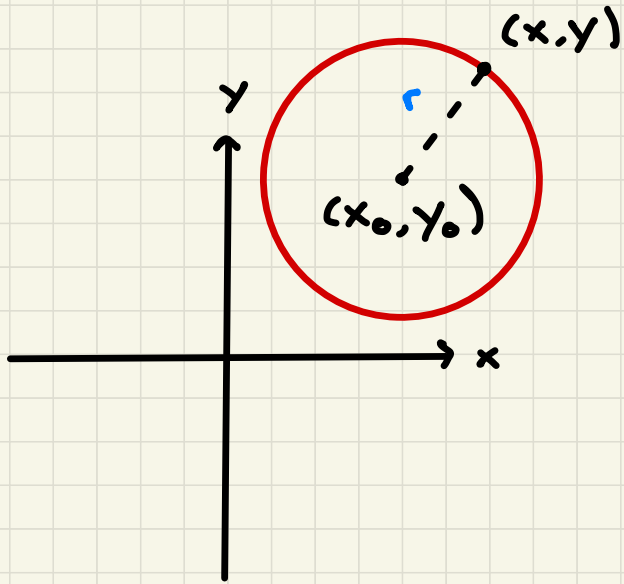

$$(x-x_0)^2 + (y-y_0)^2 + (z-z_0)^2 = r^2$$

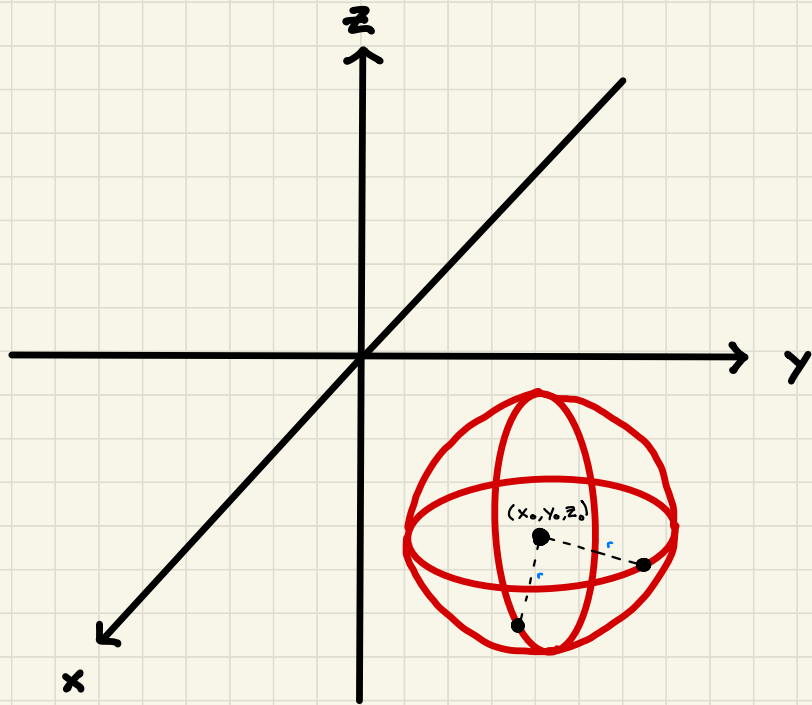

Equation of a sphere

A sphere of radius r and center (x_0, y_0, z_0)

is represented by the equation

$$(x-x_0)^2 + (y-y_0)^2 + (z-z_0)^2 = r^2$$

If (x, y, z) satisfies this equation,

then it is at distance r away from

$$(x_0, y_0, z_0)$$

Equation of a sphere

$$(x-x_0)^2 + (y-y_0)^2 + (z-z_0)^2 = r^2$$

Example: Show that $x^2 + 6x + y^2 - 4y + z^2 - 2z - 100 = 0$ is the eq of a sphere and find the radius/center.

Idea: complete the square

$$x^2 + 6x = (x+3)^2 - 9$$

$$y^2 - 4y = (y-2)^2 - 4$$

$$z^2 - 2z = (z-1)^2 - 1$$

$$(x+3)^2 - 9 + (y-2)^2 - 4 + (z-1)^2 - 1 - 100 = 0$$

$$\Rightarrow (x+3)^2 + (y-2)^2 + (z-1)^2 = 114$$

\Rightarrow center is $(-3, 2, 1)$

radius is $\sqrt{114}$

Regions defined by multiple inequalities

$$1 \leq y \leq 2, \quad x \leq 0$$

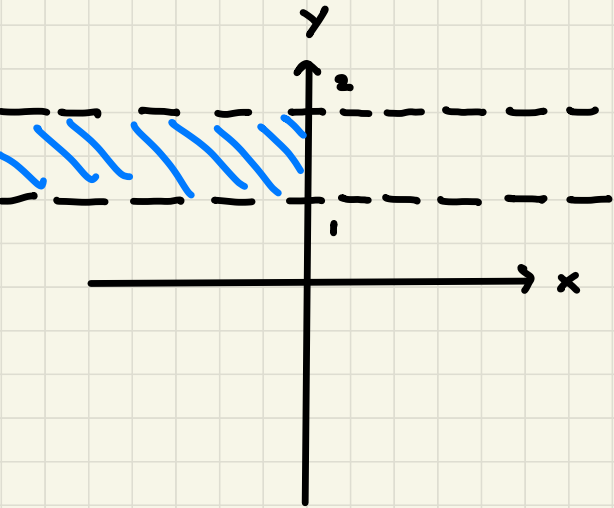

$$1 \leq z \leq 2$$

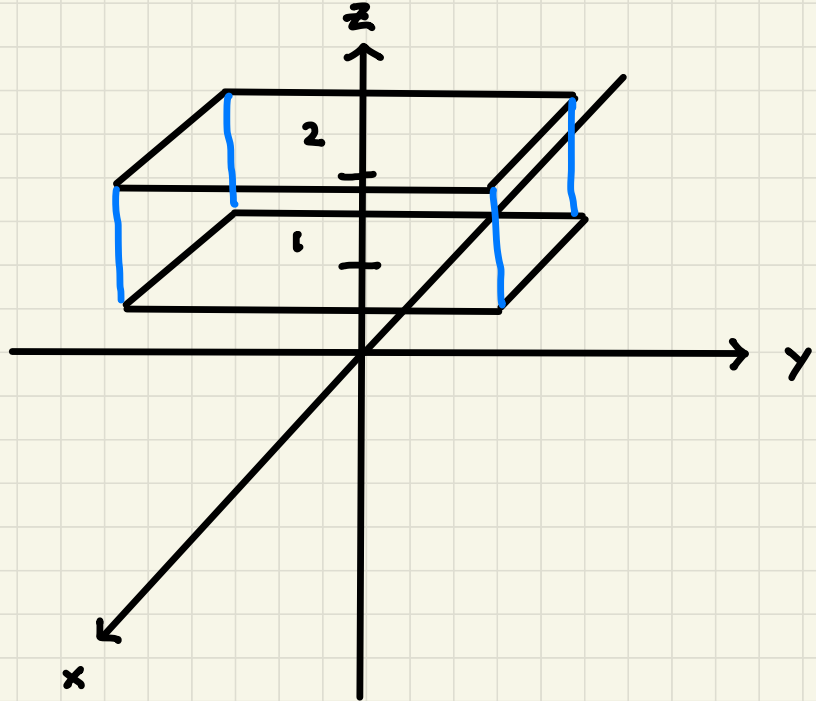

Moral: must satisfy
all constraints

Regions defined by multiple inequalities

$$4 \leq x^2 + y^2 + z^2 \leq 9$$

$$z \leq 0$$

↑
not yet

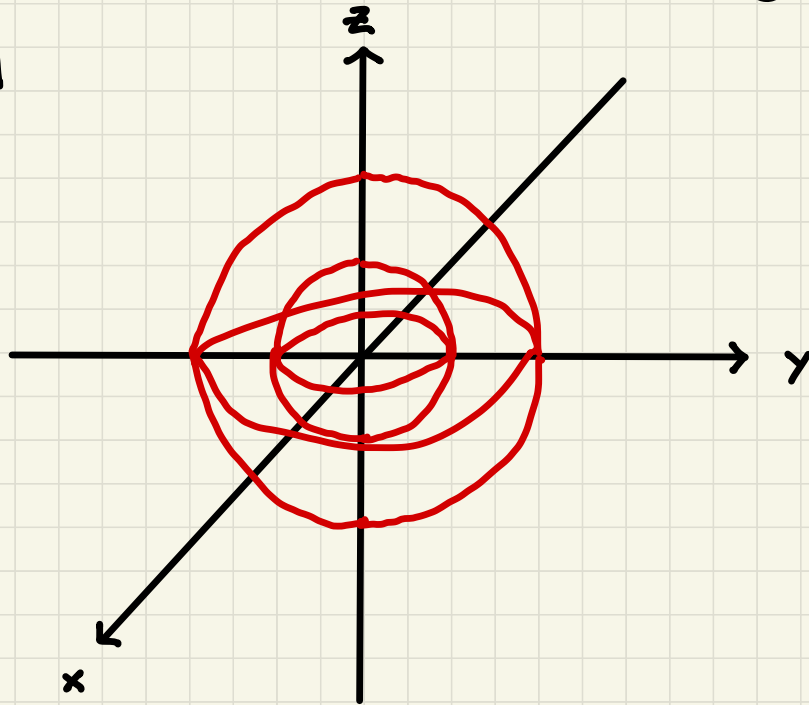

Moral: must satisfy
all constraints

Regions defined by multiple inequalities

$$4 \leq x^2 + y^2 + z^2 \leq 9$$

$$z \leq 0$$

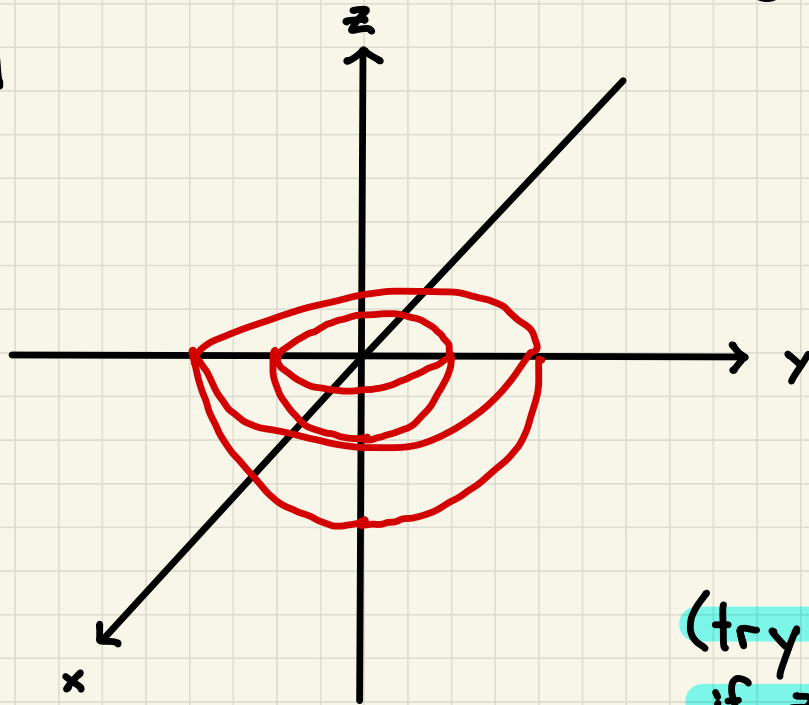

Moral: must satisfy all constraints

(try to visualize if $z \leq 0$ replaced by $z \leq +1$)