

# MULTICLASS QUEUEING NETWORKS AND SRBMS IN THE ORTHANT

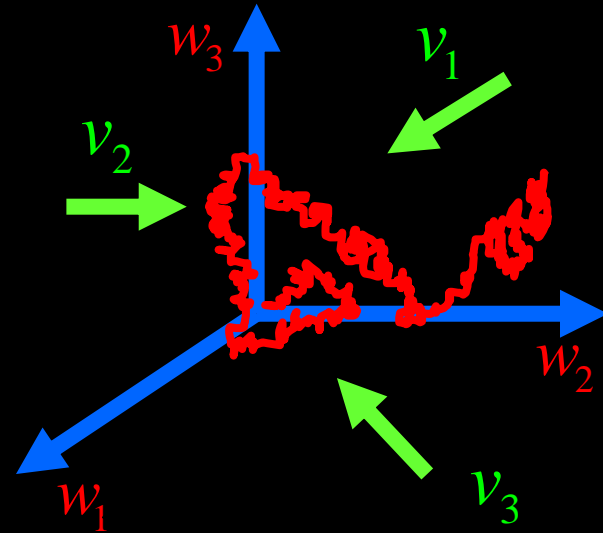
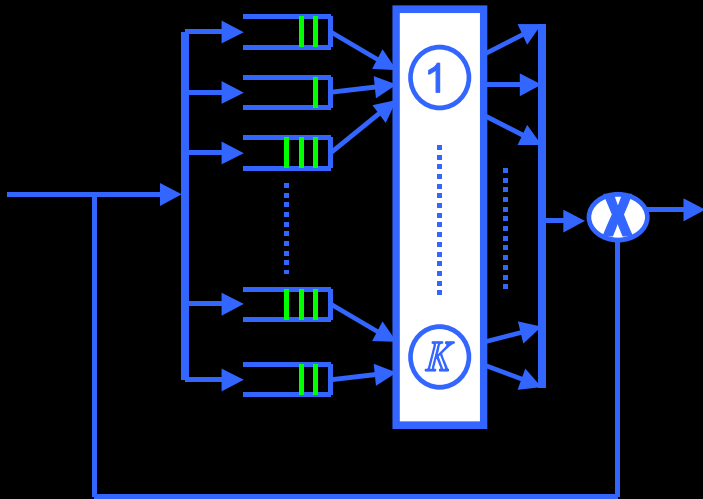

**Ruth J. Williams**  
**University of California, San Diego**

# Outline

- SIMPLE MULTICLASS EXAMPLE
- OPEN MULTICLASS HL NETWORK (CONJECTURES)
- HISTORY
- SEMIMARTINGALE REFLECTING BROWNIAN MOTIONS IN THE ORTHANT
- FURTHER DEVELOPMENTS

# SIMPLE MULTICLASS EXAMPLE

# Multiclass FIFO Station

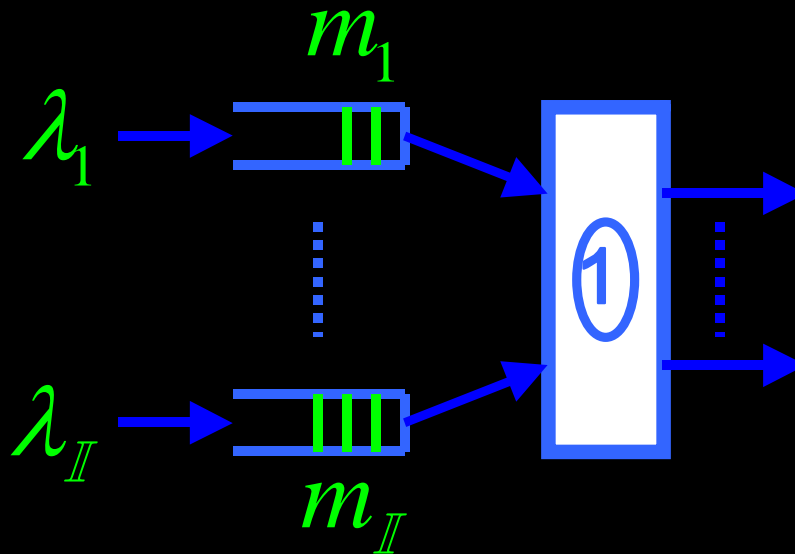

- Renewal arrivals to class  $i$  at rate  $\lambda_i$
- i.i.d. service times for class  $i$ , mean  $m_i$
- Service discipline: FIFO across all classes

# Performance Processes

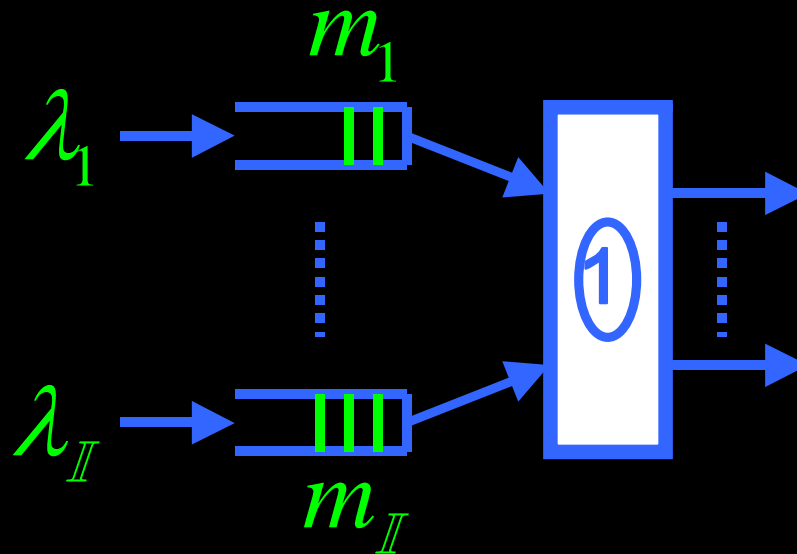

- Queue length for class  $i$ :  $Q_i$
- Workload:  $W$
- Idle time:  $Y$

# Stability

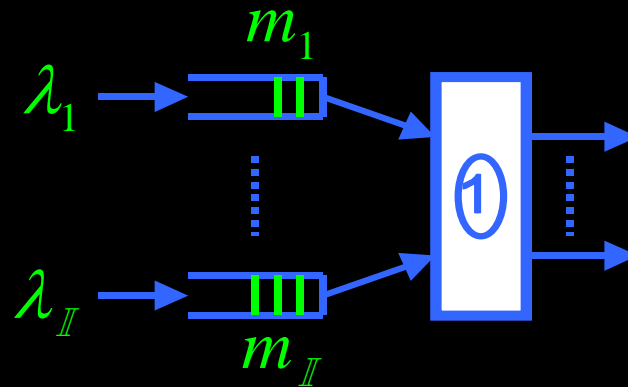

•Traffic Intensity  $\rho_1 = \sum_{i=1}^I \lambda_i m_i$

•Stability iff  $\rho_1 < 1$

# Stability

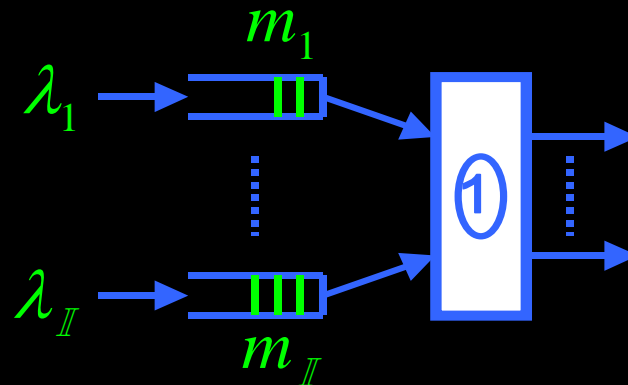

•Traffic Intensity  $\rho_1 = \sum_{i=1}^I \lambda_i m_i$

•Stability iff  $\rho_1 < 1$

•Heavy traffic  $\rho_1 \approx 1$

# Simulation of a Multiclass FIFO queue

(Poisson arrivals, exponential service times)

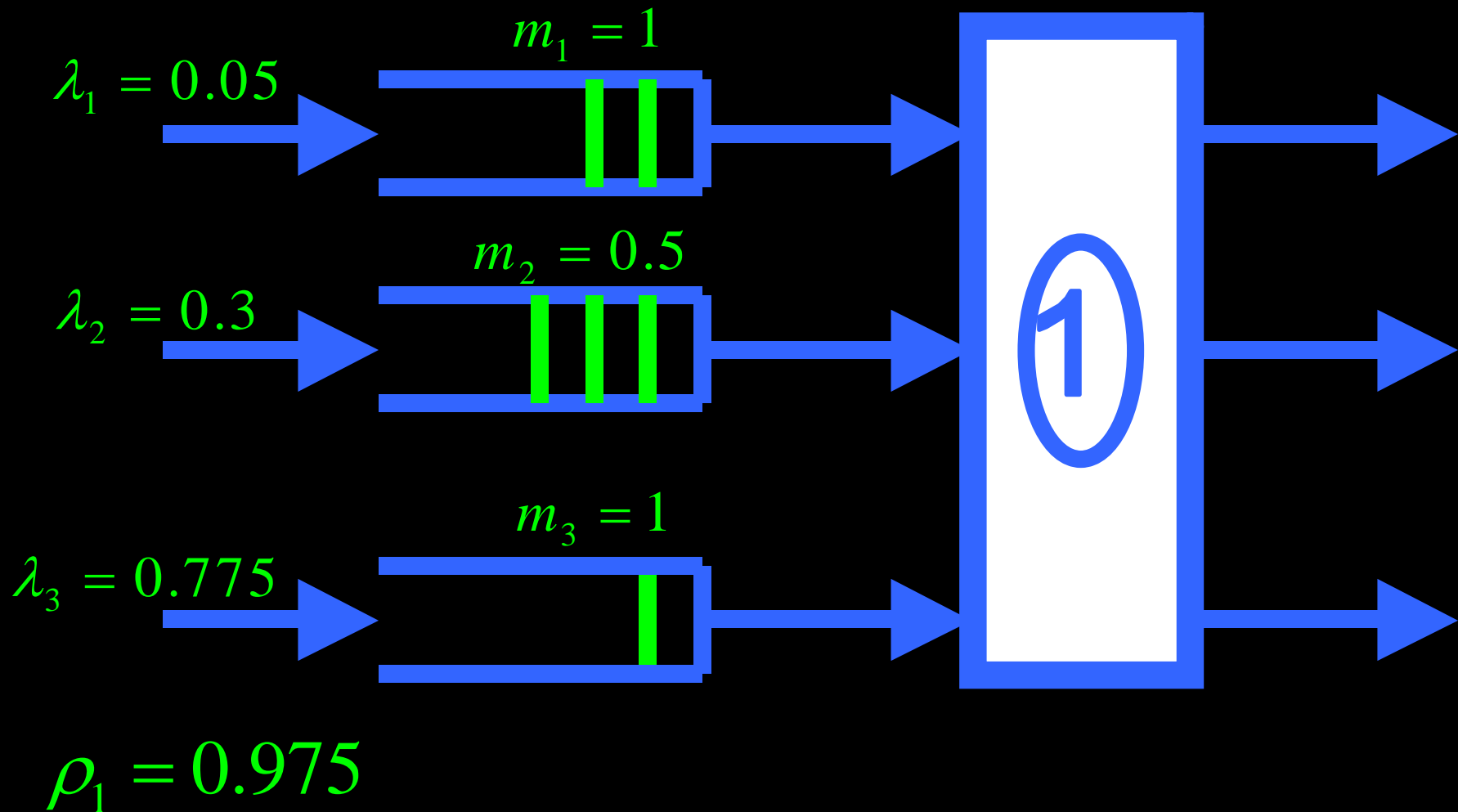

# Simulation of a Multiclass FIFO queue

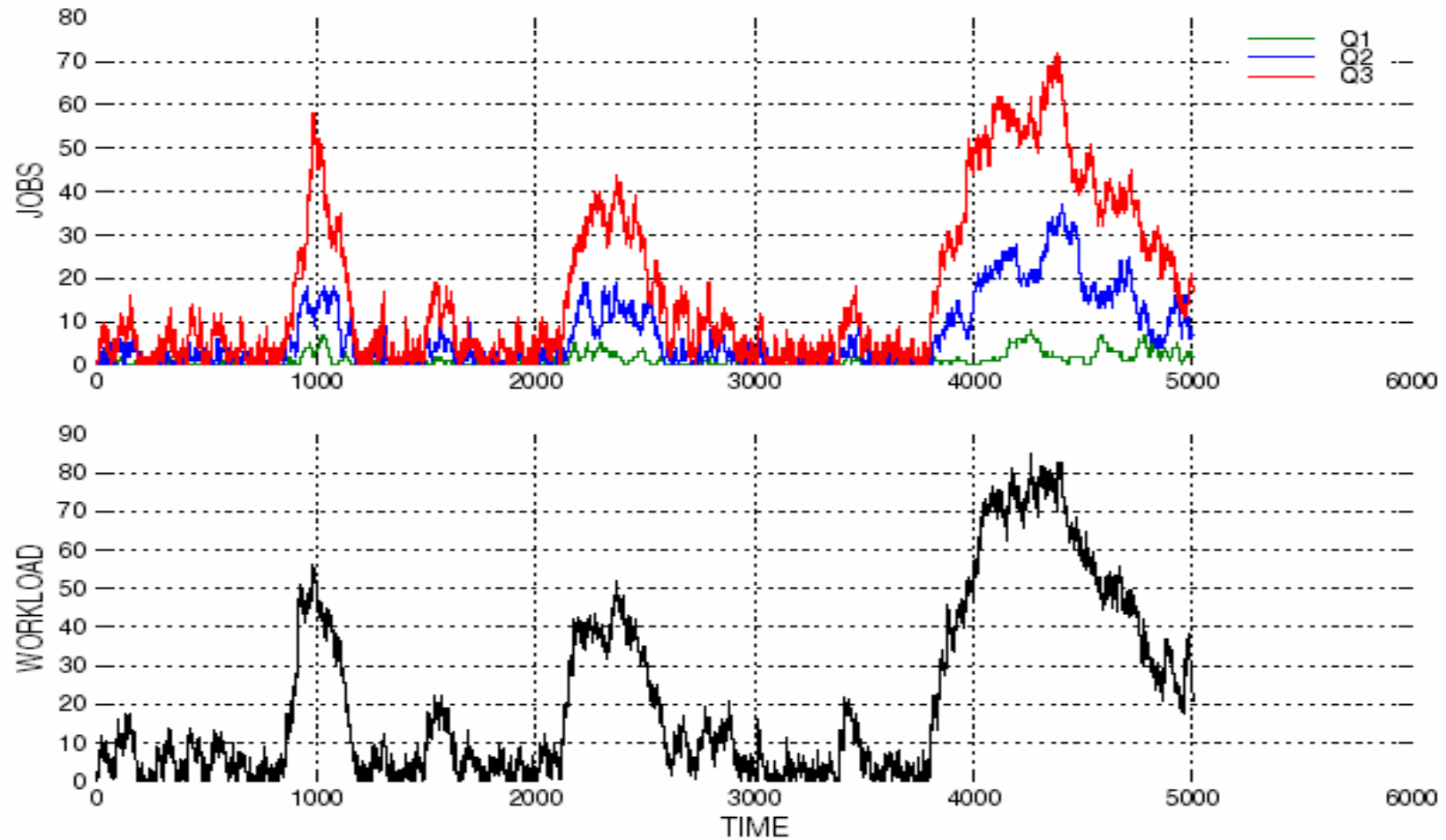

# Stability

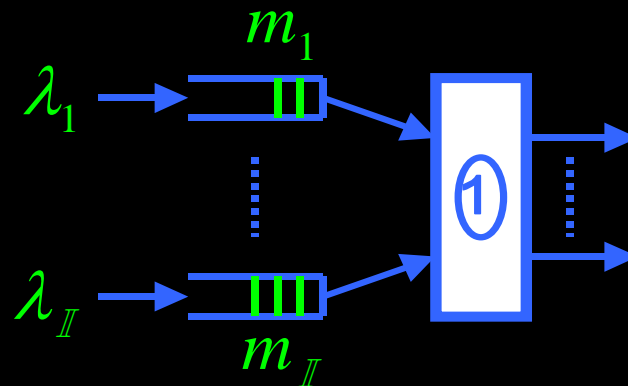

•Traffic Intensity  $\rho_1 = \sum_{i=1}^I \lambda_i m_i$

•Stability iff  $\rho_1 < 1$

•Heavy traffic  $\rho_1 \approx 1$  (assume  $\rho_1 = 1$  for simplicity)

# Heavy Traffic Diffusion Approximation

$$\hat{W}^r(t) = W(r^2t)/r, \quad \hat{Y}^r(t) = Y(r^2t)/r,$$

$$\hat{Q}_i^r(t) = Q_i(r^2t)/r, \quad i = 1, \dots, I$$

Theorem (Whitt '71)  $(\hat{W}^r, \hat{Y}^r, \hat{Q}^r) \Rightarrow (W^*, Y^*, Q^*)$   
where  $W^*$  is a one-dimensional reflecting Brownian motion with local time  $Y^*$  and  $Q^* = \lambda W^*$  (state space collapse).

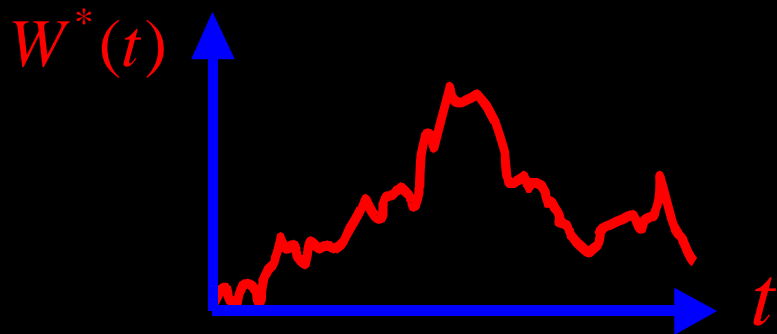

$$W^*(t) = X^*(t) + Y^*(t)$$

$$Y^*(t) = \sup\{-X^*(s) : 0 \leq s \leq t\}$$

$$X^* = \text{Brownian motion}$$

**OPEN MULTICLASS  
HL NETWORK  
(CONJECTURES)**

# Assumptions

- **Open:** jobs enter the system from outside and eventually leave the network. Assume infinite capacity buffers.
- **HL:** jobs within a buffer are stored in the order in which they arrived and service is always given to the job at the head-of-the-line. Also, the discipline is non-idling.
- Primitive arrival, service and routing processes are assumed to satisfy functional central limit theorems.

# Open Multiclass HL Queueing Network

## First order parameters

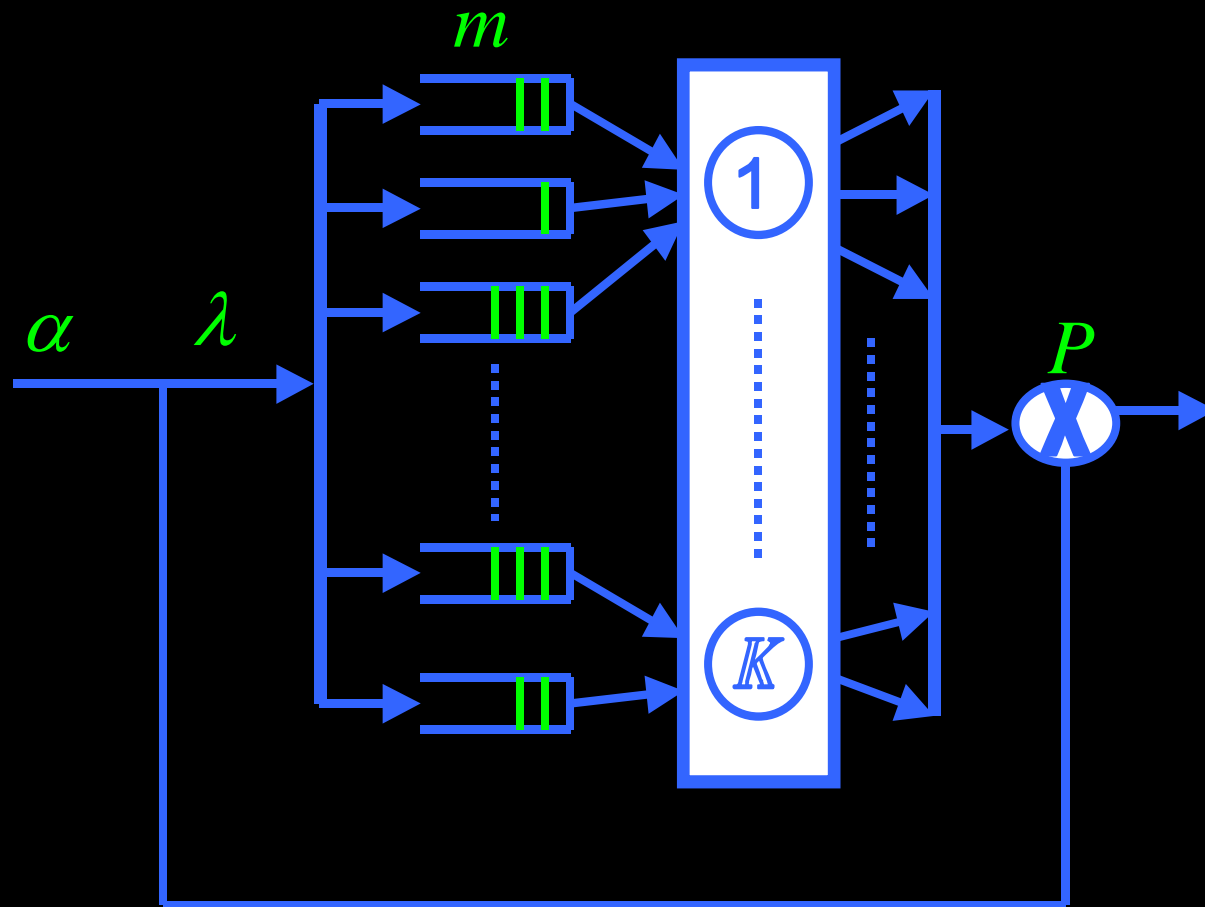

$$\lambda = \alpha + P' \lambda$$

$$\rho_k = \sum_{i \in k} \lambda_i m_i, \quad k = 1, \dots, K$$

# Natural Conjectures

- Stability: Network is stable provided

$$\rho_k < 1 \text{ for each } k = 1, \dots, K$$

- Heavy traffic diffusion approximation:

If  $\rho_k \approx 1$ ,  $k = 1, \dots, K$ , then  $(\hat{W}^r, \hat{Y}^r, \hat{Q}^r) \approx (W^*, Y^*, Q^*)$

where  $Q^* = \Delta W^*$  for some  $K \times K$  lifting matrix  $\Delta$

(that depends on the HL service discipline), and

$W^* = X^* + RY^*$  is a reflecting Brownian motion (RBM) in the  $K$ -dimensional orthant.

# HISTORY

# Affirmative Answers

(Refs. are for diffusion approximations through early 1990s)

## ■ SINGLE CLASS (FIFO):

- Single station: Borovkov ('67), Iglehart-Whitt ('70)
- Acyclic network: Iglehart-Whitt ('70), Tandem queue: Harrison ('78)
- Network: Reiman ('84), Chen-Mandelbaum ('91)

## ■ MULTICLASS:

- Single station, priorities: Whitt ('71), Harrison ('73)
- Network, priorities: Johnson ('83, SP), Peterson ('91, feedforward)
- Single station, feedback, round robin & FIFO: Reiman ('88), Dai-Kurtz ('95)

**Rely on continuous mapping construction of SRBM and do not cover multiclass networks with general feedback.**

# Counterexamples

(two-stations, deterministic routing)

## ■ STABILITY

- Kumar and Seidman ('90): clearing policy.
- Lu and Kumar ('91): static priorities, deterministic interarrival and service times.
- Rybko and Stolyar ('92): static priorities, exponential interarrival and service times. (See also Botvitch and Zamyatin ('92))
- Seidman ('94): FIFO, deterministic interarrival and service times.
- Bramson ('94): FIFO, exponential interarrival and service times.

## ■ DIFFUSION APPROXIMATION

- Dai-Wang ('93): FIFO, exponential interarrival and service times.

# HL MQN: Sufficient Conditions

## ■ STABILITY

- Subcritical fluid models

## ■ PERFORMANCE ANALYSIS (in heavy traffic)

- Reflecting diffusions and state space collapse via critical fluid models

**SEMIMARTINGALE REFLECTING  
BROWNIAN MOTIONS  
(SRBMs)**

# SRBM DATA

- State space:  $\mathbb{R}_+^K$
- Brownian statistics: drift  $\theta$ , covariance matrix  $\Gamma$
- Reflection matrix:  $R = (v_1, \dots, v_K)$

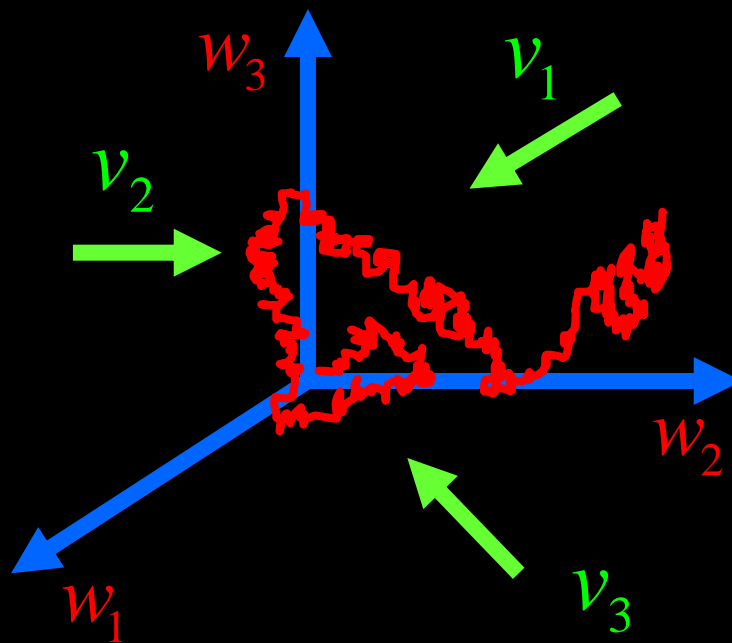

# SRBM DEFINITION (w/starting point $x_0$ )

A continuous  $\mathbb{K}$ -dimensional process  $W$  such that

(i)  $W = X + RY$

(ii)  $W$  has paths in  $\mathbb{R}_+^{\mathbb{K}}$

(iii) for  $k=1, \dots, \mathbb{K}$ ,  $Y_k(0) = 0$ ,  $Y_k$  is continuous,

non-decreasing, and it can increase only when  $W_k = 0$

(iv)  $X$  is a  $(\theta, \Gamma)$  BM s.t.  $X(0) = x_0$ ,

$\{X(t) - \theta t, t \geq 0\}$  is a martingale relative to the filtration generated by  $(W, X, Y)$

# Necessary Condition for Existence

Defn:  $R$  is completely- $S$  iff for each principal submatrix  $\tilde{R}$  of  $R$  there is  $\tilde{y} > 0 : \tilde{R}\tilde{y} > 0$

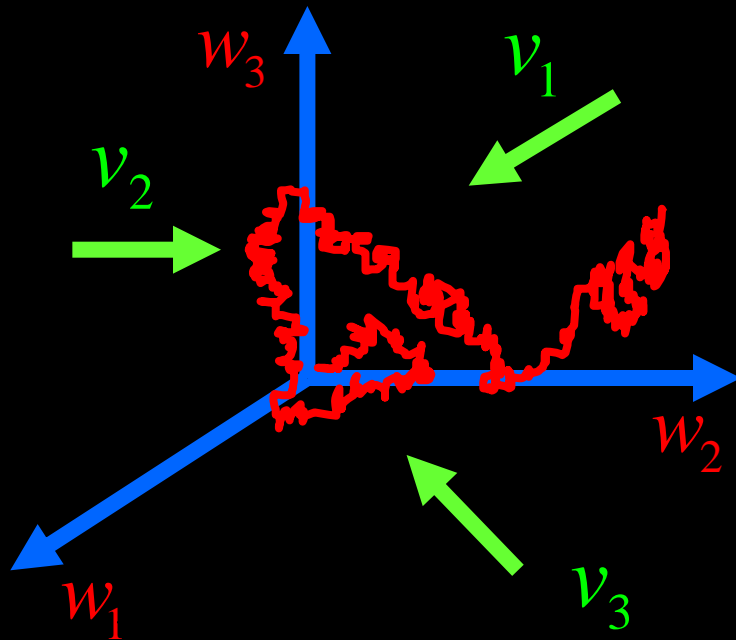

$$R = (v_1, \dots, v_K)$$

# Existence and Uniqueness in Law

Theorem (Reiman-W '88, Taylor-W '93)

There is an SRBM  $W$  starting from each point  $x_0$  in  $\mathbb{R}_+^K$  iff  $R$  is completely-S. In this case, each such SRBM is unique in law and these laws define a continuous strong Markov process.

# Oscillation Inequality

Assume that  $R$  is completely- $S$ . There is a constant  $C > 0$  such that whenever  $\delta > 0$ ,  $0 \leq t_1 < t_2 < \infty$ , and  $w, x, y$  are r.c.l.l. satisfying

(i)  $w(t) = x(t) + Ry(t)$  for  $t \in [t_1, t_2]$

(ii)  $w$  lives in  $\mathbb{R}_+^K$

(iii) for  $k=1, \dots, K$ ,  $y_k(t_1) \geq 0$ ,  $y_k$  is continuous, non-decreasing, and can increase only when  $w_k < \delta$ ,

Then

$$\text{Osc}(w, [t_1, t_2]) + \text{Osc}(y, [t_1, t_2]) \leq C(\text{Osc}(x, [t_1, t_2]) + \delta)$$

Cts case: Bernard-El Kharroubi '91, discts case: W '98

# Analysis of multidimensional SRBMs

## ■ Sufficient conditions for positive recurrence

Dupuis-W '94, Chen '96, Budhiraja-Dupuis '99, El Kharroubi-Ben Tahar-Yaacoubi '00

## ■ Stationary distribution

- *Characterization*: Harrison-W '87, Dai-Harrison '92, Dai-Kurtz '98
- *Analytic solutions -two-dimensions*: Foddy '84, Trefethen-W '86, Harrison '06
  - product form*: Harrison-W '87
- *Numerical methods*: Dai-Harrison '91, '92, Shen-Chen-Dai-Dai '02, Schwerer '01

## ■ Large deviations

Majewski '98, '00, Avram-Dai-Hasenbein '01, Dupuis-Ramanan '02,

# Some Related Work on RBMs & Queueing Networks

- Capacitated queues (convex polyhedral domains)
  - Dai-Williams '95, Dai-Dai '99
- HT limits that are not SRBMs (& have no state space collapse)
  - Single station-polling: Coffman-Puhalskii-Reiman '95
  - Dynamic HLPS: Dupuis-Ramanan '99, Ramanan-Reiman '03
- Non-HL service disciplines  
(Markovian state descriptor is typically infinite dimensional)
  - LIFO preemptive resume: Single station: Limic '00, '01
  - Processor sharing: Single station (Gromoll-Puha-W '01, Puha-W '03, Gromoll '03); network (stability: Bramson '04)
  - EDF: Single station (Doytchinov-Lehoczký-Shreve '01), acyclic network (Kruk-Lehoczký-Shreve-Yeung '03), network (stability: Bramson '01)

# PERSPECTIVE

**MQN**

**SPN**

**HL**

Sufficient conditions for  
stability and diffusion  
approximations

e.g., parallel server system,  
packet switch

**Non-  
HL**

e.g., LIFO, Processor Sharing  
(single station,  
PS: network stability)

e.g., Internet congestion  
control / bandwidth sharing  
model